

ASSEMBLY INSTRUCTIONS

Perform flaring according to SAE J533. See Fig. 2.
See Table 1 below for dimensions.

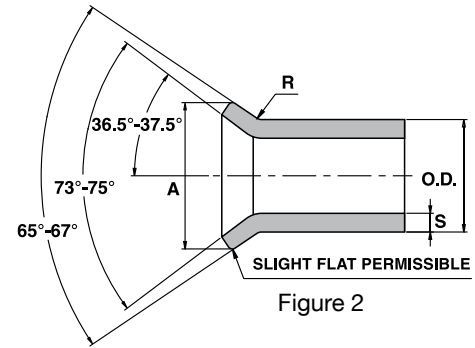

Figure 2

TABLE 1: FLARING

Nominal Tube O.D.	A Single Flare Diameter				R		S		DEBURRING PRIOR TO FLARING
	inch		mm		inch	mm	inch	mm	
	Max	Min	Max	Min	±0.02	±0.5	Max	Min	
1/8	0.20	0.18	5.08	4.58	0.03	0.8	0.035	0.88	To ensure satisfactory flare production, tube end deburring might be required prior to flaring. It is usually necessary to break the inside corner smoothly before single flaring. In addition, some non-ferrous tubing is normally required to eliminate the cutoff burr, which might otherwise create leakage paths across a substantial portion of the flare. Smoothly breaking the outside corner prior to single flaring, or both the outside and inside corners prior to double flaring, is acceptable for any tube material to minimize splitting.
3/16	0.28	0.26	7.11	6.61	0.03	0.8	0.035	0.88	
1/4	0.36	0.34	9.14	8.64	0.03	0.8	0.065	1.65	
5/16	0.43	0.40	10.92	10.16	0.03	0.8	0.065	1.65	
3/8	0.49	0.46	12.44	11.69	0.04	1.0	0.065	1.65	
1/2	0.66	0.63	16.76	16.01	0.06	1.5	0.083	2.1	
5/8	0.79	0.76	20.06	19.31	0.06	1.5	0.095	2.41	
3/4	0.95	0.92	24.13	23.37	0.08	2.0	0.109	2.76	
7/8	1.07	1.04	27.17	26.42	0.08	2.0	0.109	2.76	
1	1.20	1.17	30.48	29.72	0.09	2.3	0.12	3.04	
1 1/8	1.38	1.35	35.05	34.29	0.09	2.3	0.12	3.04	
1 1/4	1.51	1.48	38.35	37.60	0.09	2.3	0.12	3.04	
1 1/2	1.73	1.70	43.94	43.18	0.11	2.8	0.12	3.04	

Dimensions are for reference only, and subject to change without notice.

TABLE 2: ALLOWABLE WORKING PRESSURE RATINGS
(CAPABLE OF 4" TO 1" MIN. BURST)

Nom. SAE Dash Size	Nom. Tube O.D Inches	37° Flare Straight Thread	Nom. Pipe Size	SAE St.Threads Union and Bulkhead	Fittings with Pipe Threads	NOTE:
2	1/8	5/16" - 24	1/8"	5000	5000	As many factors influence the pressure at which a system will or will not perform satisfactorily, values shown in Table 2 should not be construed as guaranteed minimum.
3	3/16	3/8" - 24	1/8"	5000	5000	
4	1/4	7/16" - 20	1/8"	5000	5000	
5	5/16	1/2" - 20	1/8"	5000	5000	
6	3/8	9/16" - 18	1/4"	5000	5000	
8	1/2	3/4" - 16	3/8"	4500	4000	
10	5/8	7/8" - 14	1/2"	3500	3000	
12	3/4	1 1/16" - 12	3/4"	3500	3000	
14	7/8	1 3/16" - 12	3/4"	3000	2500	
16	1	1 5/16" - 12	1"	3000	2000	
20	1 1/4	1 5/8" - 12	1 1/4"	2500	1150	
24	1 1/2	1 7/8" - 12	1 1/2"	2000	1000	
32	2	2 1/2" - 12	2"	1500	1000	